

“T” Type Collars

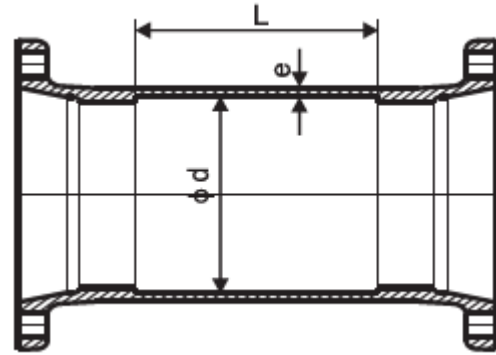

“K” Type Collars

Class K 12

Nominal Dia (DN)	e	d	SHORT TYTON COLLAR (Non Standers Mass)	STD TYTON COLLAR		M/J COLLAR		
				L	App. Mass (Kg)	L	App. Mass (Kg)	
							Main Fittings	Complete Set Wt.
80	7.0	109	6	160	9	160	9	14
100	7.2	130	7	160	11	160	11	17
125	7.5	156	9	165	17	165	17	24
150	7.8	183	11	165	18	165	18	27
200	8.4	235	16	170	23	170	23	33
250	9.0	288	19	175	32	175	32	45
300	9.6	340	24	180	40	180	40	58
350	10.2	393	32	185	55	185	55	79
400	10.8	445	40	190	70	190	70	100
450	11.4	498	47	195	82	195	82	116
500	12.0	550	52	200	94	200	94	134
600	13.2	655	80	210	120	210	120	170
700	14.4	760	-	220	178	220	178	254
750	15.0	810	-	225	198	225	198	290
800	15.6	865	-	230	225	230	225	335
900	16.8	970	-	240	272	240	272	402
1000	18.0	1075	-	250	343	250	343	513
1100	19.2	1180	-	260	430	260	430	670
1200	20.4	1285	-	270	500	270	500	780
1400	22.8	1477	-	340	680	340	680	1080
1500	24.0	1580	-	350	780	350	780	1140
1600	25.2	1683	-	360	940	360	940	1440
1800	27.6	1892	-	380	1180	380	1180	1760

NOTE : Size & Dimensions in **RED** are non standard as per IS 9523-2000